

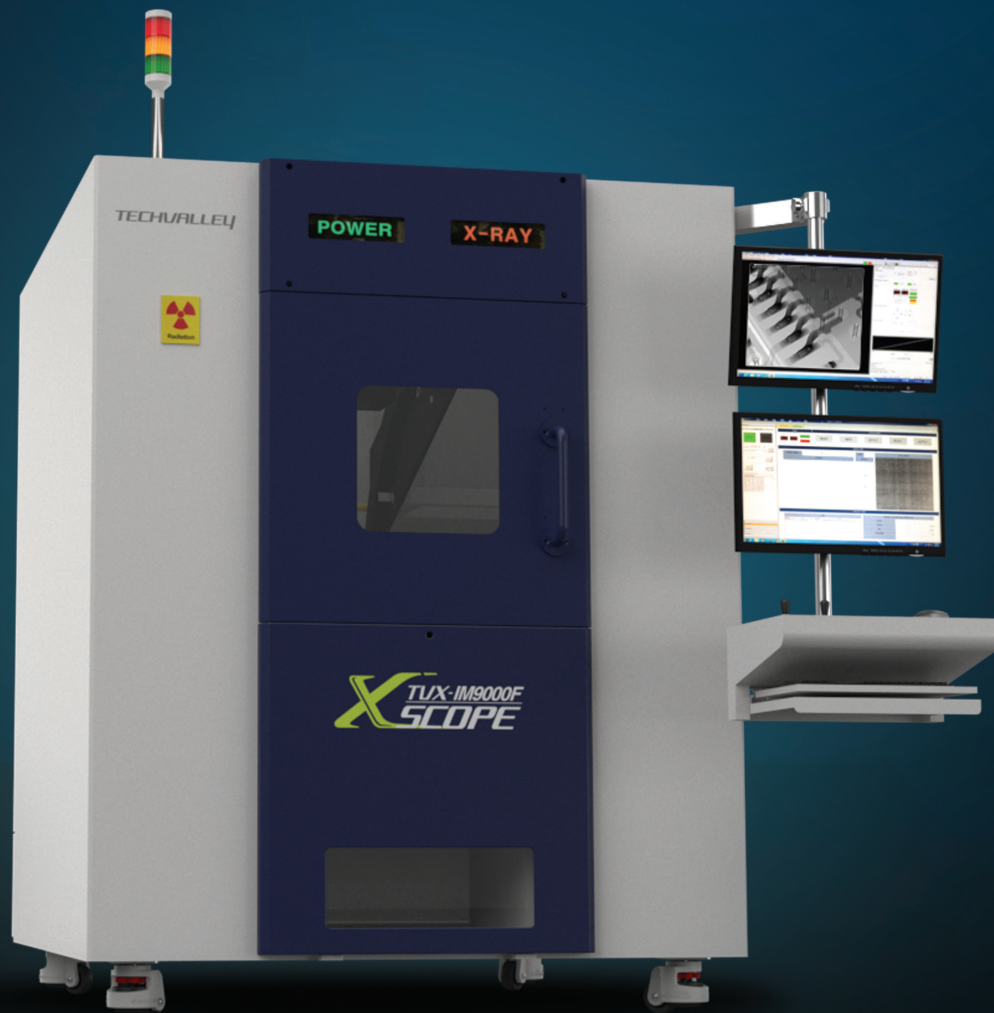

Automated X-ray Inspection

**TECHVALLEY**

**EUROPE**



# TVX-IM9000F

Off-line Automatic X-ray Inspection System

[techvalley-europe.com](http://techvalley-europe.com)

# TVX-IM9000F

Off-line automatic X-ray inspection system

iTOP Technology based on AI platform

TVX-IM13000DX  
TVX-IM9000F  
HAWKEYE6000L

## Highest possible cost effectiveness at-line/ offline solution with excellent quality.

The TVX-IM9000F is a high performance compact micro focus system, providing excellent image quality.

An ideal production or research & development tool, offering precision measurement and analysis. A highly cost-effective solution for all x-ray inspection tasks, from batteries to PCBA's

## Key Features

- Off-line automatic X-ray inspection equipment can be easily controlled and programmed, with a variety of automatic inspection solutions
- The TVX-IM9000F is capable of inspecting 500mm x 500mm and 5kg samples at one time and can be used for various products

## Benefits

- Large and heavy product inspection possible (500mm x 500mm, 5kg)
- Can be equipped with automatic inspection function
- Provides clear images including distance, diameter, angle measurements, and enhanced filters
- Detector tilt function does not reduce magnification
- Applying automatic inspection according to the customer's needs

## Inspection Images

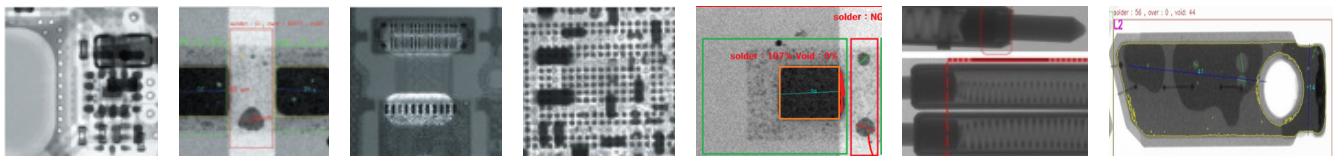

## Applications



Mobile Parts

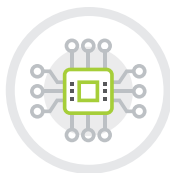

PCB/FPCB



Camera Module



Intenna/ Antenna

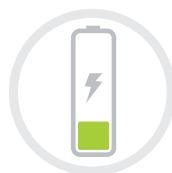

Batteries

### Techvalley Europe

Phone +36 70 394 3428  
Email [sales@techvalley-europe.com](mailto:sales@techvalley-europe.com)  
Web [techvalley-europe.com](http://techvalley-europe.com)

# Specification

	TVX-IM13000DX	TVX-IM9000F	HAWKEYE6000L
--	---------------	-------------	--------------

## X-Ray Tube

Tube Type	Sealed Type	Sealed Type	Sealed Type
Inspection Resolution Max.	2µm	1µm	2µm
Field of View	4x4 ~ 45x45 (mm)	2x2 ~ 45x45 (mm)	4x4 ~ 30x30 (mm)
Max. Tube Voltage	130kV	110kV	110kV
Max. Tube Current	320uA	250uA	250uA
Power	16W	25W	25W

## X-Ray Imaging

Detector	Flat Panel Detector	Flat Panel Detector	Flat Panel Detector
Flat Panel Detector	5 inch	5 inch	5 inch
Resolution	6.9 Megapixels	6.9 Megapixels	6.9 Megapixels

## Manipulator

Table Size (mm)	500 x 500	500 x 500	600 x 800 ~ 1200
Axis	Standard: 4axis (X, Y, Z, Tilt)	Standard: 4axis (X, Y, Z, Tilt)	Standard: 6axis
Stroke (mm)	X: 500 / Y: 500 / Z:200	X: 500 / Y: 500 / Z:200	X: 600mm / Y: 1200mm / Z:200mm
Max. Sample Loading (Kg)	5kg	5kg	5kg
Tilt (°)	55 °	55 °	45 °

## Hardware

Dimension (WxDxH)	1400x2250x1650	1372x1534x1623	1500x2000x1900 mm
Weight	2500Kg	1400kg	1500Kg
Power Consumption	Max. 5KW	Max. 3KW	Max. 3KW
Electricity	220V, 1 Phase	220V, 1 Phase	220V, 1 Phase
Air	None	None	5kg/cm <sup>2</sup> , 6mm(Ø)

## Dimensions

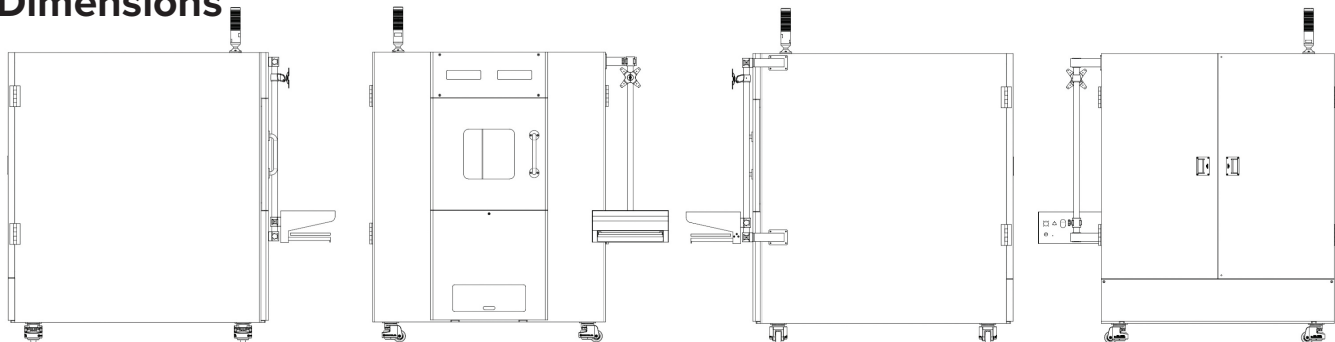

**Please note** | Specifications are subject to change without notice.



Automated X-ray Inspection  
**TECHVALLEY**  
**EUROPE**

## EUROPEAN DISTRIBUTORS

### **Techvalley Europe HQ**

Hunyadi Janos utca 3.,  
Building "A", H-1117  
Budapest, Hungary  
sales@techvalley-europe.com  
+36 70 394 3428

### **Techvalley Europe Demo & Technical Support Center**

Hunyadi Janos utca 3.,  
Building "A", H-1117  
Budapest, Hungary  
support@techvalley-europe.com  
+36 70 394 3428

### **Altus Group Ltd UK, Ireland**

Unit D, Crescent Trade Park Moons,  
Moat Drive, Redditch,  
Worcestershire, B98 9DZ, UK  
sales@altusgroup.co.uk  
+44(0)1386 791 074  
altusgroup.co.uk

### **SmartRep GmbH Germany, Austria, Switzerland**

Martin-Luther-King-Str. 2b D-63452  
Hanau, Germany  
info@smartrep.de  
+49(0)6181 440 87-50  
smartrep.de

### **Danutek Hungary Kft Hungary, Ukraine, Serbia**

Hunyadi Janos utca 3.,  
Building "A", H-1117  
Budapest, Hungary  
sales@techvalley-europe.com  
+36 70 394 3428  
sales@danutek.com  
+361 273 04 57  
danutek.com

### **Danutek Balkans SRL Romania, Bulgaria, Macedonia**

Mitopolit Andrei Saguna 2, 300119  
Timisoara, Romania  
office@danutek.com  
+40 356 802 800  
danutek.com

[techvalley-europe.com](http://techvalley-europe.com)