

AUTO DISPENSING SYSTEM

■ ADS-700 Series ■

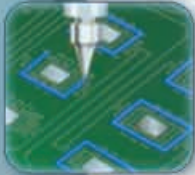
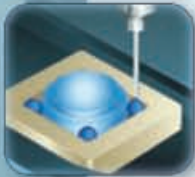

FEATURES ■

High-speed and High-accuracy capability unique to the dispensing system delivers higher productivity.

(빠른 속도와 높은 정밀도에 의해 보다 많은 생산성을 실현하는 장비이다.)

Uniform dispensing achieved and beautiful work edge dispensing without splash.

(작업 시 항상 일정한 정량과 잔사가 남지 않으며 작업 후 형상이 균일하다.)

The powerful programming is possible to simulate the head work in order to check with camera.

(실제 작업 위치를 카메라로 보면서 가상 작업하는 것을 확인 가능하다.)

Easy dispensing point teaching by vision & MPG handle and include an internet service function.

(비전과 조그 핸들에 의한 쉬운 프로그램 운영 및 인터넷 서비스가 가능하다.)

Dispensing system provides many kinds of underfill, wire bond, dam, fill, glob top and die attach dispensing.

(디스펜스 장비는 언더필, 와이어본드, 댐, 충전, 본딩, 다이본드 등 다양한 작업이 가능하다.)

Integrated electronic controls and software as well as robot for a wide variety of IMPEC applicators.

(IMPEC은 본체의 로봇, 전장 및 소프트웨어를 자체 개발하여 제조하고 있다.)

Auto Dispensing System **ADS-700 Series**

System Dimensions

Width:	1200mm
Depth:	1390mm
Height:	1650mm
Weight:	Approx 550kg

Programmable axis

Drive method:	Multi AC Servo Motor X, Y, Z, and R(Optional) axis
Servo repeatability:	±0.015mm
Moving speed:	1,000mm/sec for each axis

PCB Handling

Table travel:	X: 500, Y: 400, Z: 100(mm)
Max clearance:	50mm above PCB
Work area:	450(X)mm x 350(Y)mm
PCB Thickness:	Max 2.4mm

System Programming

Color CCD camera vision direct teaching system
and MPG handle function

Program data HDD memory

Line, Arc, Circle, Spline

MDI, Jog

Utilities

Voltage:	220V, 1Phase 50/60Hz, 2.0Kva or 380V, 3Phase 50/60Hz, 2.0kva
Pressure:	6 bar (90psi)
Flow:	200L/min

Control

IMPEC dispensing control software

Industry PC control for Window xp

TFT LCD 15" touch monitor

Software features

Low air pressure alarm

User password protection

Error message display

Interface SMEMA compatible

Dispensing description (user select)

Super-small, constant-volume dispensing valve

Needle control valve

Piston control valve

Uniform coating valve

High pressure valve

Diaphragm valve

Fluid drip prevention valve

Film coating achieved with specialized valve

Options

Motor width adjustment conveyor

Multi action dispenser head

Dual simultaneous applicator capability

Laser height sensor

Pressure tank unit

Low fluid sensor or Low fluid scale

Valve heating

Bar code recognition system

Fiducial check & tilting system

※ Specifications in this brochure are subject to change for better performance without prior notice.

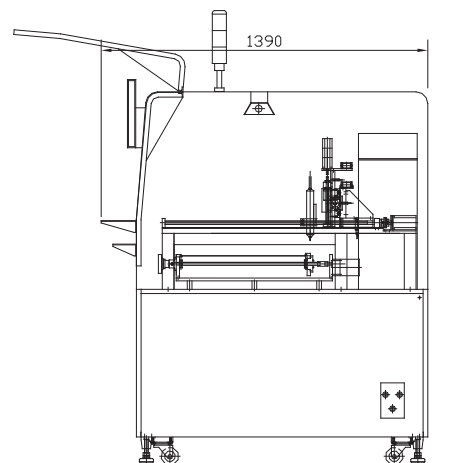
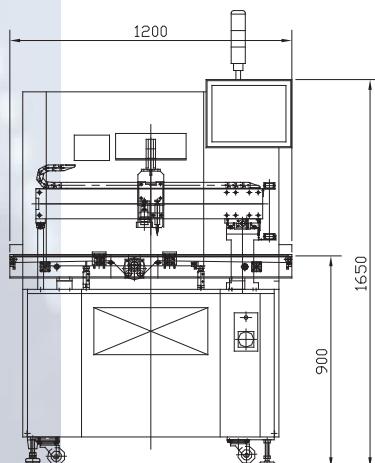

IMPEC Enterprise Co., Ltd.

<http://www.impec.com> E-mail : impec@impec.com